

Product datasheet

Mechanical cushion seal dock shelter

Type: PMK

Contact:

Ronnenberger Straße 20
D-30989 Gehrdenphone +49 (0) 5108 879 270
fax +49 (0) 5108 879 2710info@promstahl.de
www.promstahl.de

Mechanical cushion seal dock shelter (PMK)

The PROMStahl PMK dock seal is designed for loading and unloading truck fleets consisting of vehicles almost identical in width and height. It guarantees perfect protection from draught, rain and wind and thus prevents energy losses.

The dock seal is equipped with a horizontal cushion and two vertical cushions consisting of foam material completely covered by a PVC-coated high-resistance Trevira fabric. The dimensions of the dock seals are defined depending on the individual characteristics of your loading bay and the vehicle types to be loaded/unloaded i.e. your PROMStahl dock seal is always tailor-made.

The PMK dock shelter is pre-mounted and consists of just three parts; therefore, it can be mounted to the façade very fast and easily. Considerable savings regarding time and money are the decisive advantages of this design.

To minimize wear of your cushion seal, we recommend to additionally equip your docking station with our rubber buffer PGF 140.

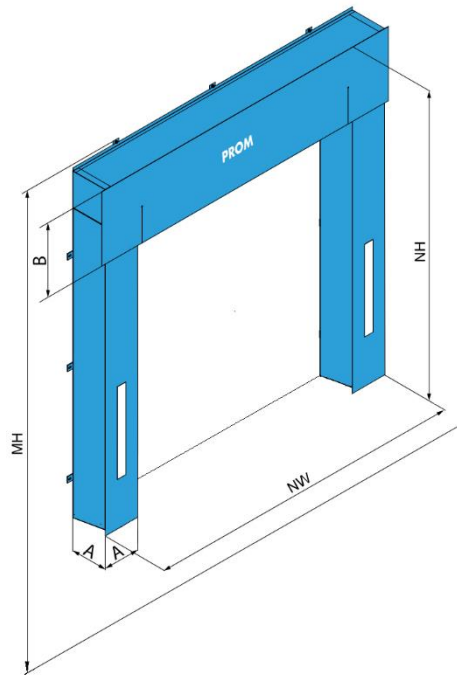

- NW Nominal width
- NH Nominal height
- MH Installation height
(Recommendation 4100 mm)
- A Cushion width / Cushion depth
- B Height of the top curtain

	Standard dimensions
Nominal width of the dock shelter (NW)	2600, 2800
Nominal height of the dock shelter (NH)	2500, 2700, 2900
Cushion cross section: (A)	300x300
Height of the top curtain (B)	600
All dimensions in mm.	

Further dimensions are available on request.

Options

- Number on the top curtain
- Yellow warning stripes
- angled side cushions: they allow for exact docking in the case of a heavily slanted yard level

Curtain specification

Front curtain

- double-layer PVC-coated polyester cloth
- total weight: about 2520 g/m² in accordance with the EN ISO 2286-2 standard
- material thickness: 2 mm
- temperature stability: -25° C/ +70° C
- low flammability in accordance with the DIN 75200 standard
- tensile strength / maximum tensile force in accordance with DIN EN ISO 1421/V1
 - longitudinal tensile strength: about 4000N/ 50 mm
 - transverse tensile strength: about 3800N/ 50 mm
- tear propagation strength in accordance with DIN 53363
 - longitudinal tear propagation strength: about 500 N
 - transverse tear propagation strength: about 500 N

Top and side cushion curtain

- single-layer PVC-coated polyester cloth
- total weight: about 600 g/m² in accordance with EN ISO 2286-2
- material thickness: 0,5 mm
- temperature stability: -40° C/ +70° C
- low flammability in accordance with DIN 75200
- tensile strength / maximum tensile force in accordance with DIN EN ISO 1421/V1
 - longitudinal tensile strength: about 2000 N/ 50 mm
 - transverse tensile strength: about 2000 N/ 50 mm
- tear propagation strength in accordance with DIN 53363
 - longitudinal tear propagation strength: about 200 N
 - transverse tear propagation strength: about 150 N

Wall fixing

- Fixing elements for concrete (heavy duty)

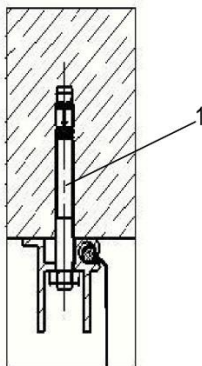

heavy-duty bolt W-FA M10x30 (WÜRTH)

- Fixing elements for aerated autoclaved concrete (maximum wall thickness: 300 mm)

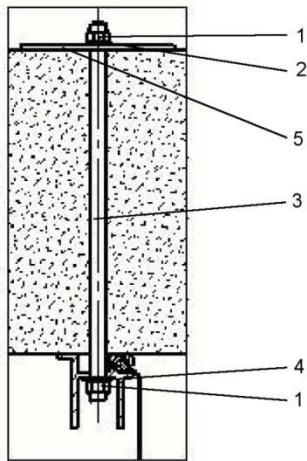

- 1 hexagonal nut
- 2 spring washer
- 3 threaded bolt
- 4 spacer
- 5 shim

- Fixing elements for ISO material (wall thickness 60 mm, 80 mm, 100 mm)

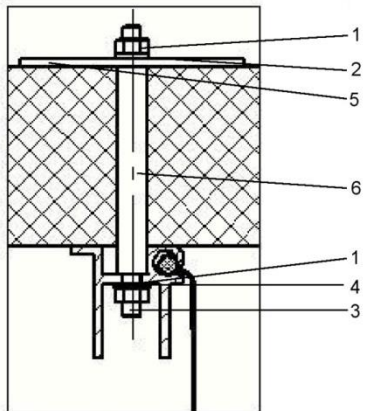

- 1 hexagonal nut
- 2 spring washer
- 3 threaded bolt
- 4 spacer
- 5 shim
- 6 spacer tube

- Fixing elements for plain sheet material (plain sheet thickness 3 mm)

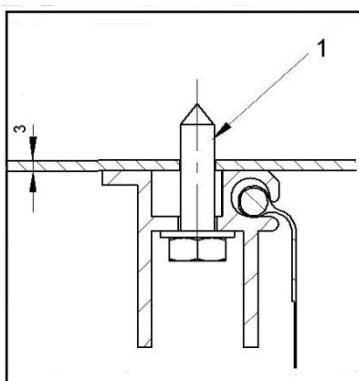

- 1 self-tapping screw