

1 2 3 4 5 6 7 8

A B C D E F

SCHNITT A-A

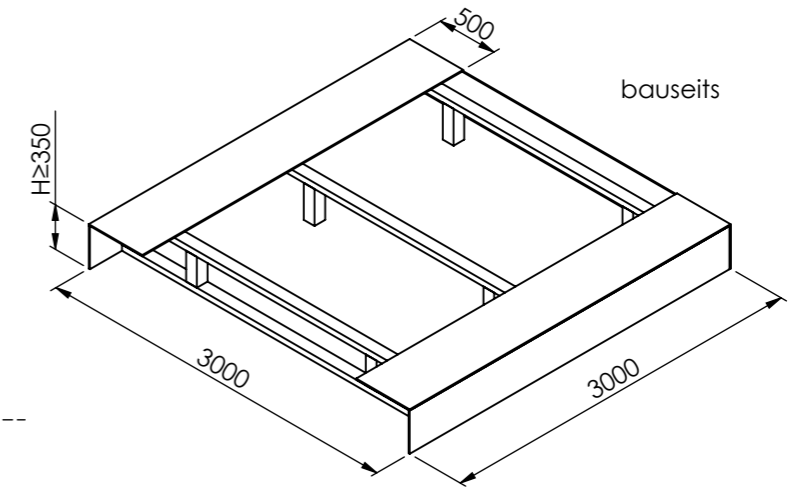
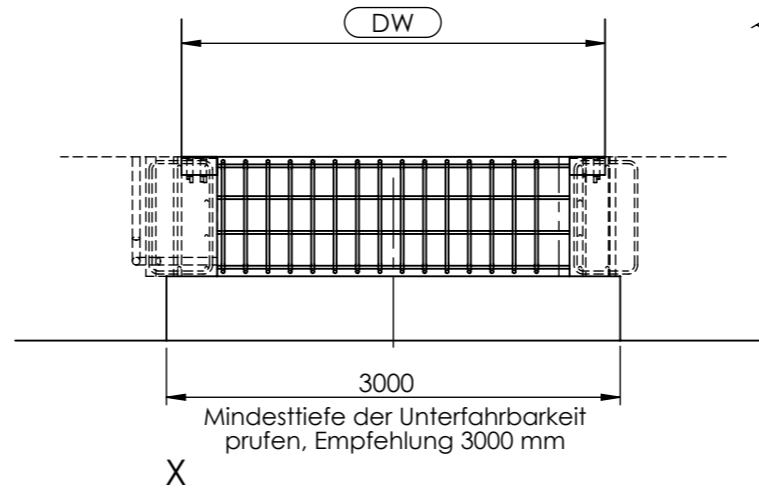
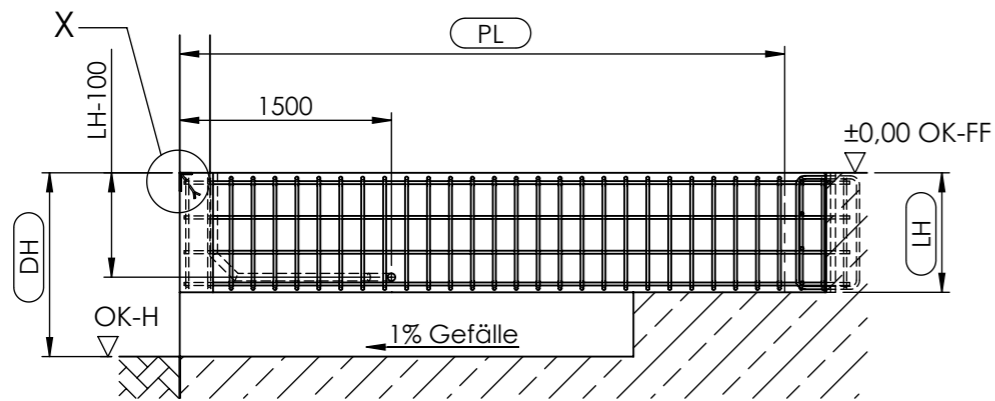

Tragkraft	F1
60 kN	57 kN
80 kN	76 kN
100 kN	95 kN

Lasten

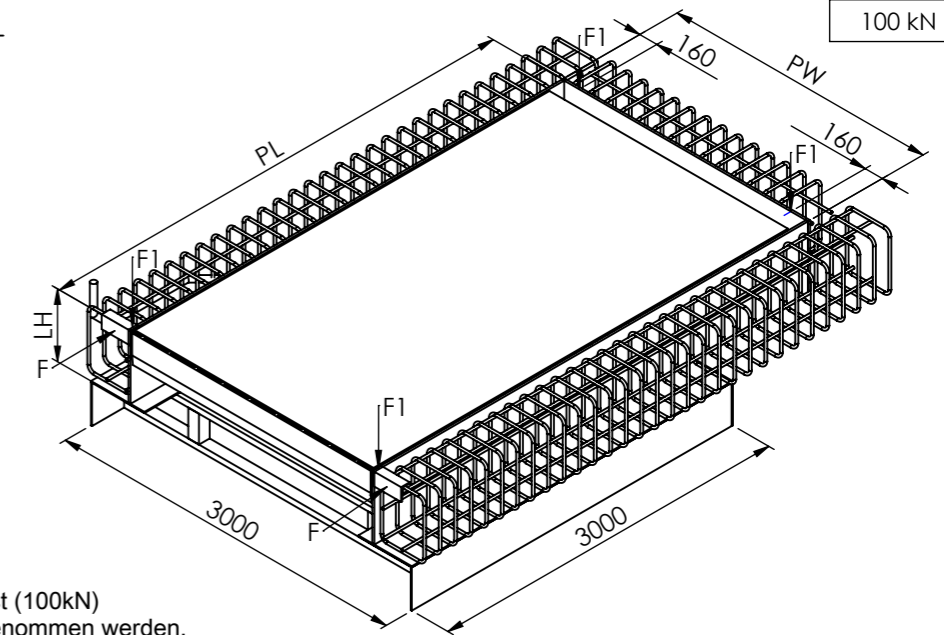

F = Die horizontale Anpralllast (100kN) muß vom Bauwerk aufgenommen werden.
F1= Ruhelage

Leerrohre wahlweise rechte oder linke Ausführung gezeichnet: rechte Ausführung

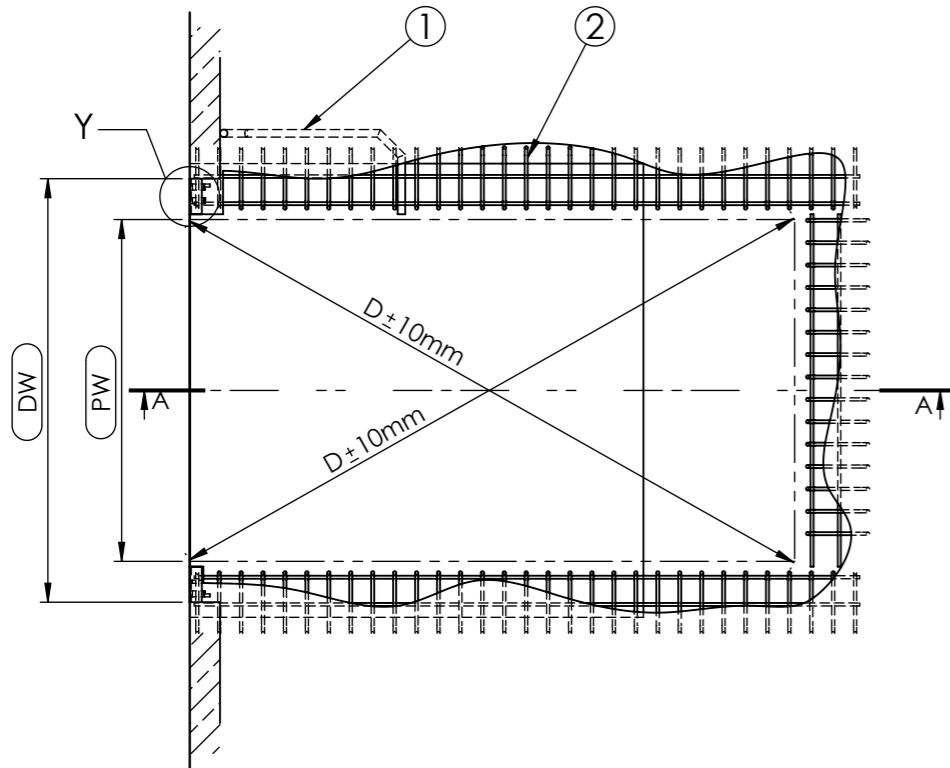
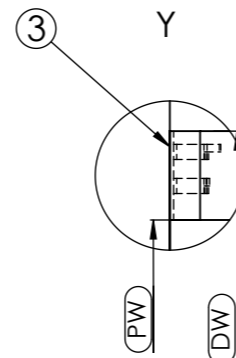
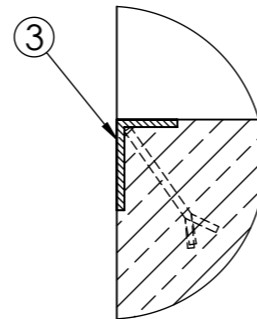

Einbaustelle gezeichnet: NL=4000
NW=2200
LH=800

NL	1750	2000	2000	2500	2500	2750	2750	3000	3000	3500	4000	4500
PL	1805	2055	2055	2555	2555	2805	2805	3055	3055	3555	4055	4555
LH	700	600	700	600	700	600	700	600	700	800	800	800

NW	PW
1750	1880
2000	2130
2100	2230
2200	2330
2250	2380
2400	2530

ABMESSUNGEN IN MM

DO NOT SCALE DRAWING

REVISION C

	NAME	SIGNATURE	DATE
DRAWN	R. Stuszczyk		24.05.2023
CHK'D			
APPV'D			
MFG			
Q.A			

PJP MAKRUM
Industrial Group
PJP MAKRUM S.A.
Plac Kościeleckich 3
85-033 Bydgoszcz
POLAND

TITLE:

PT B mit Unterfahrbarkeit

DWG NO.

PTE.00.00.25-DE

A3

SCALE:1:50

DE

F

1 2 3 4