

Vorderkante Rampe

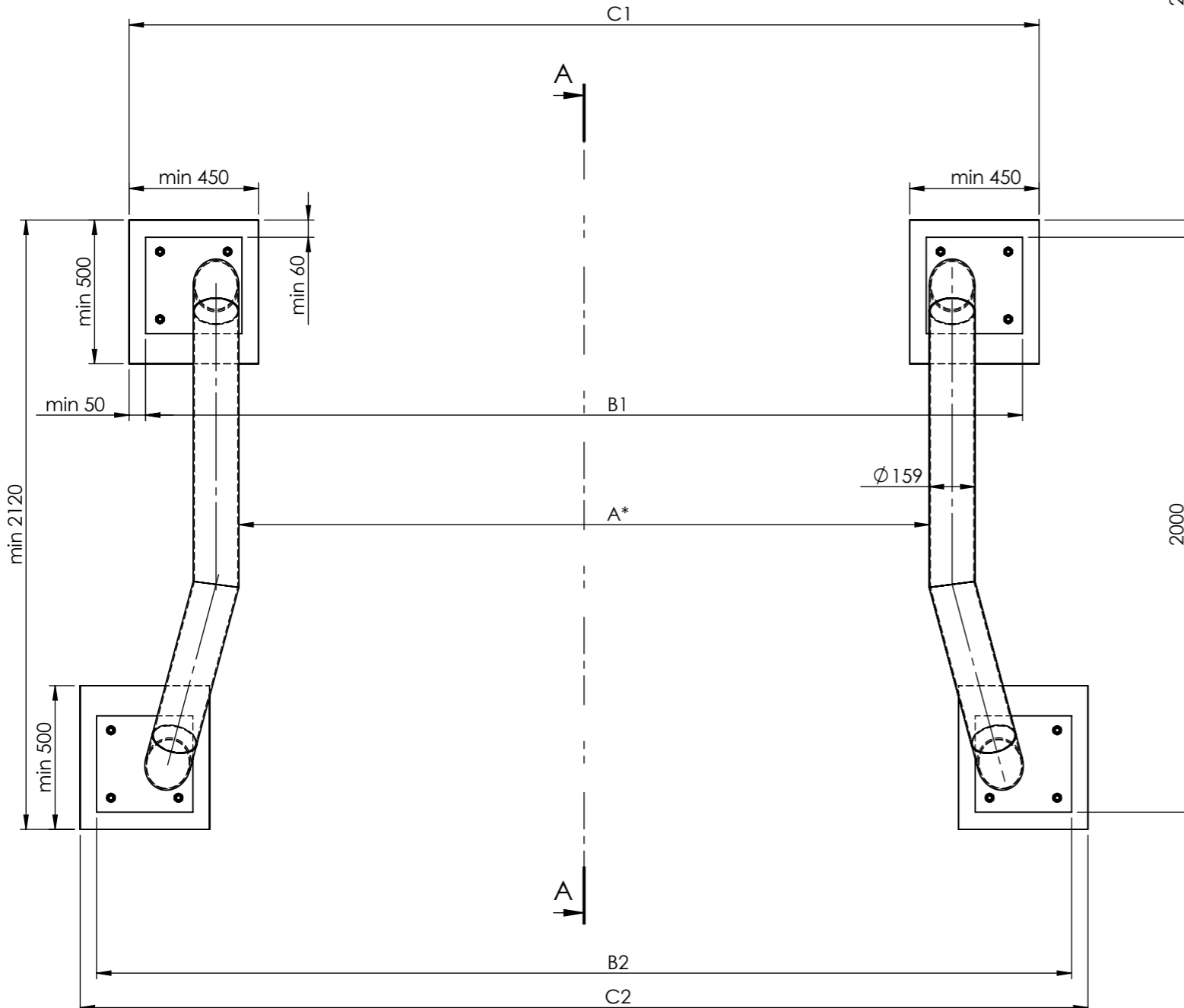

A-A

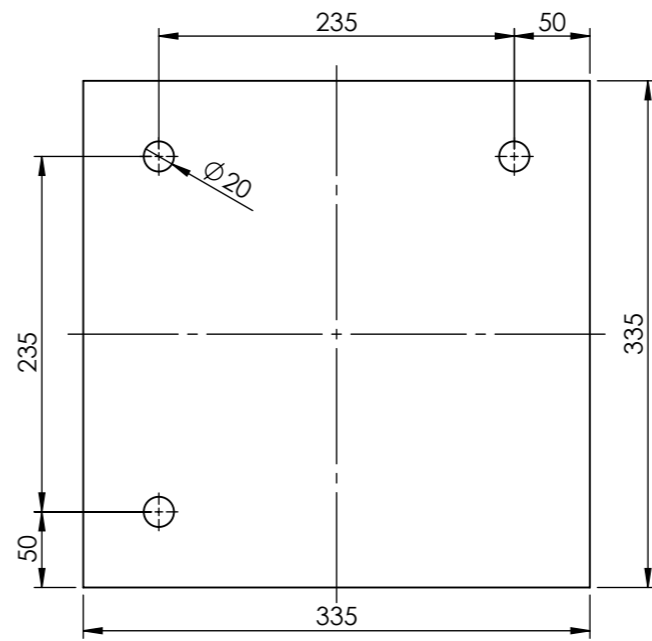
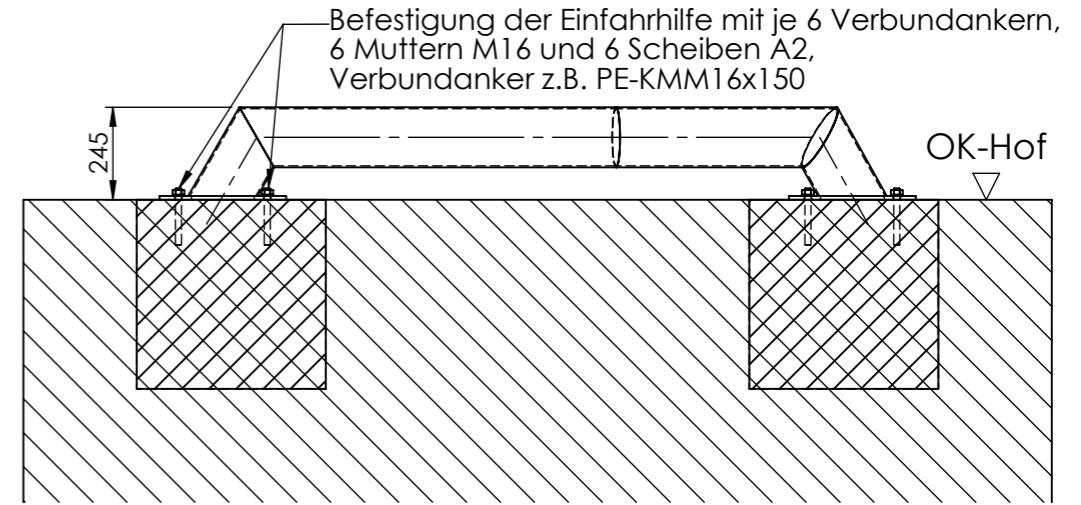

A*	B1	B2	C1	C2
2400	3050	3390	min 3165	min 3505
2500	3150	3490	min 3265	min 3605
2600	3250	3590	min 3365	min 3705

\* Bei der Abstandsbemessung auf ausreichenden Spielraum zum Fahrzeugreifen achten

Bemessung und Herstellung der Fundamente sind bauseitige Leistungen

UNLESS OTHERWISE SPECIFIED: DIMENSIONS ARE IN MILLIMETERS SURFACE FINISH: TOLERANCES: EN 22768 - m, k EN 13920 - B, F		FINISH:	DEBUR AND BREAK SHARP EDGES	DO NOT SCALE DRAWING	REVISION <b>B</b>
DRAWN M. Kozielczyk		SIGNATURE	DATE 07.12.2021	MATERIAL:	
CHK'D				TITLE: <b>Einfahrhilfe Flanschversion</b>	
APPV'D				DWG NO.	<b>PEF 2000</b>
MFG					<b>A3</b>
Q.A					
PJP MAKRUM S.A. Plac Kościeleckich 3 85-033 Bydgoszcz POLAND			WEIGHT:	SCALE:1:20	SHEET 1 OF 4

